

# Little GIANT<sup>®</sup> Pump Company

---

## PE-A SERIES

---



### Features

- Epoxy encapsulated motor
- 4.0' maximum lift
- 17 watts
- 1/8" MNPT discharge
- Impedance protected
- For submersible use only

### Construction

- Motor — 1/250 HP Epoxy Encapsulated
- Maximum Flow Rate — 70 GPH @ 1'
- Maximum Head — 4.0'
- Intermittent Liquid Temp. up to — 120° F
- Intake — Screened
- Discharge — 1/8" MNPT
- Housing — Glass-filled polyester
- Cover — Glass-filled polyester
- Volute — Glass-filled polyester
- Impeller — Polypropylene
- Shaft Seal — Viton<sup>®</sup>
- Screen — Polypropylene
- Electrical — 115V, 60HZ

Small submersible epoxy encapsulated pump designed for light duty water recirculation. Ideal for statuary and water displays. This compact 70 GPH pump features a 1/8" MNPT discharge, 4.0' shut-off head capability, screened inlet and a 6' power cord.

# Little Giant Pump Co.

## PE-A SERIES

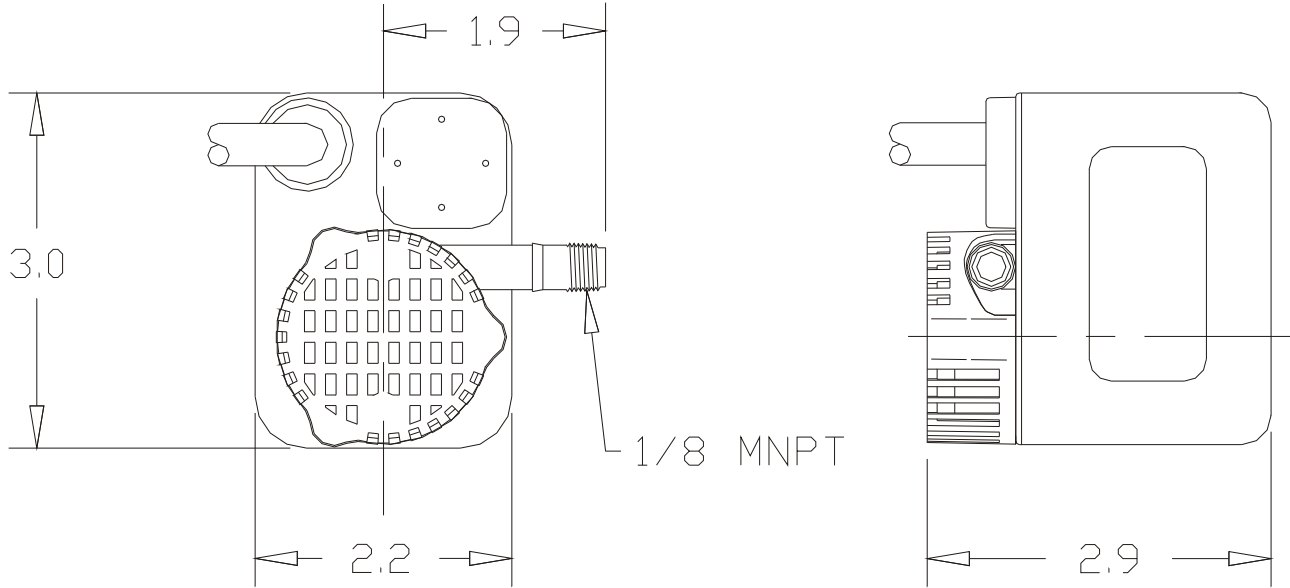

### Specifications

Model No.	Item No.	Discharge		HP	Volts	Hertz	Amps	Watts	Performance (GPH @ Head)		Shut Off		Pwr. Cord (ft)	Weight (Lbs.)
		Size	Listing(s)						1'	3'	Feet	PSI		
PE-A	518100	1/8" MNPT	UL/CSA	1/250	115	60	0.3	17	70	40	4.0	1.75	6	2.08

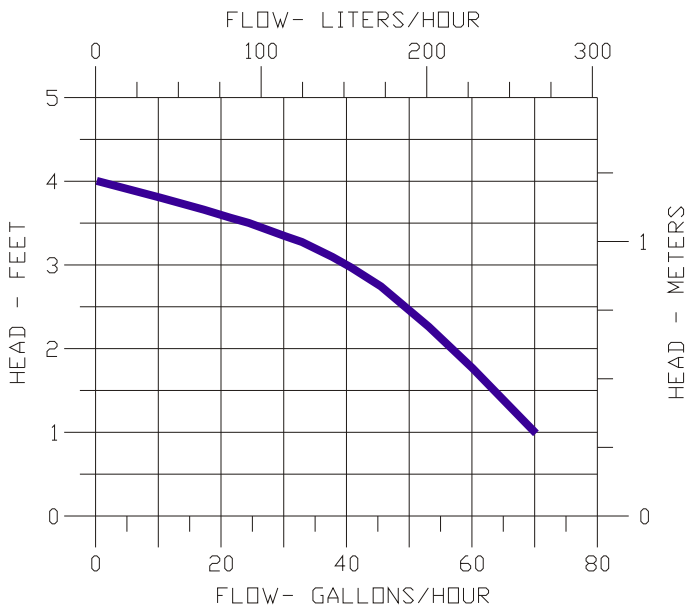

### Replacement Parts

Plate	118922
Impeller	118443
Screen	118904