



6 SERIES



Features

- Cast iron pump housing with protective epoxy coating for corrosion resistance
- Oil-filled motor housing for lifetime lubrication and rapid heat dissipation
- 1/3 HP Shaded Pole Motor
- Stainless steel screws, bolts and handle to protect against corrosion
- Mechanical seal (stainless steel spring, nitrile parts, carbon and ceramic faces) to assure maximum protection against pump failure
- Bearings: Upper and lower sintered sleeve bearings for extended motor life
- Thermal overload protection
- Manual and automatic models
- Automatic operation with pressure switch activates pump when water level is between 7" and 10". Pump shuts off when water level falls to between 1" and 4" (Pressure switch is non-adjustable)
- Automatic operation with piggyback mechanical float switch activates pump when water level is between 9" and 10-1/2". Pump shuts off when water level falls to between 2" and 3" (Pumping range is adjustable)
-   115 volt models

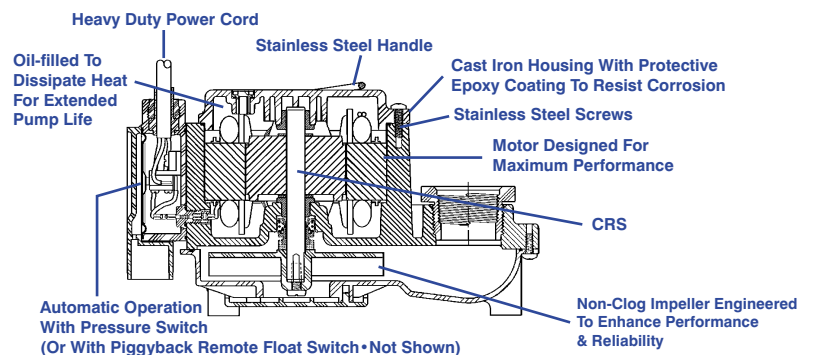

For residential and light commercial use, the Model 6 Series sump pumps provide efficient and reliable service. For extended or continuous use in moving large volumes of water, these pumps feature a 1-1/2" discharge with a maximum lift of 18', a polycarbonate cover and a polypropylene volute/base. A choice of manual or automatic versions with various switch configurations provides user with the right pump for their needs.

Little Giant Pump Co.

6 SERIES

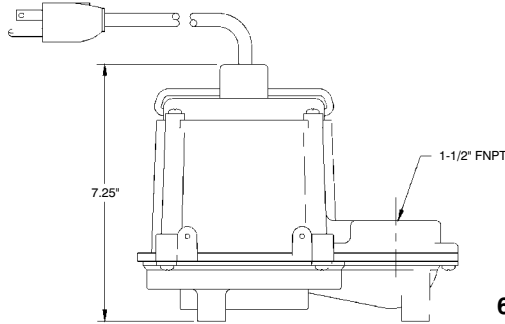

6-CIM-R

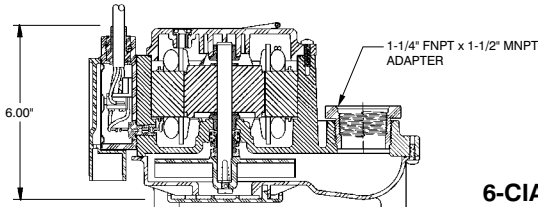
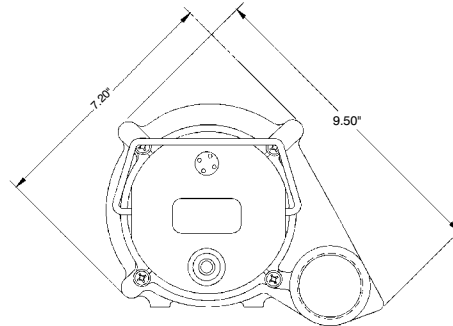

6-CIA

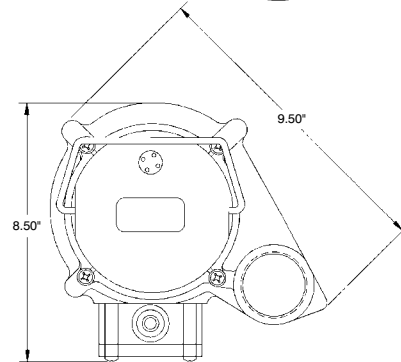

Specifications

| MODEL NO. | ITEM NO. | LISTING | HP | VOLTS | AMPS R | WATTS | FLOW (GPM@HEAD) | | | SHUTOFF HEAD (FT.) | P.S.I. | PWR. CRD. (FT.) | WEIGHT (LBS.) | DIMENSIONS (H x L x W) (IN.) |
|-------------|----------|---------|-----|-------|--------|-------|-----------------|----|------|--------------------|--------|-----------------|---------------|------------------------------|
| | | | | | | | 5 | 10 | 15 | | | | | |
| 6-CIM-R | 506271 | UL/CSA | 1/3 | 115 | 9.0 | 720 | 46 | 29 | 12.5 | 18 | 7.8 | 10 | 16.50 | 7.25 x 9.50 x 7.25 |
| 6-CIM-R | 506274 | UL/CSA | 1/3 | 115 | 9.0 | 720 | 46 | 29 | 12.5 | 18 | 7.8 | 25 | 18.00 | 7.25 x 9.50 x 7.25 |
| 6-CIA | 506125 | UL/CSA | 1/3 | 115 | 9.0 | 720 | 46 | 29 | 12.5 | 18 | 7.8 | 25 | 18.50 | 6.00 x 9.50 x 8.50 |
| *6-CIA-RS | 506267 | UL/CSA | 1/3 | 115 | 9.0 | 720 | 46 | 29 | 12.5 | 18 | 7.8 | 10 | 17.50 | 7.25 x 9.50 x 7.25 |
| 6-CIM | 506266 | UL/CSA | 1/3 | 230 | 4.5 | 720 | 46 | 29 | 12.5 | 18 | 7.8 | 12 | 18.75 | 6.00 x 9.50 x 8.50 |
| 6-CIA | 506158 | UL/CSA | 1/3 | 115 | 9.0 | 720 | 46 | 29 | 12.5 | 18 | 7.8 | 8 | 18.00 | 6.00 x 9.50 x 8.50 |
| 6-CIA | 506168 | UL/CSA | 1/3 | 115 | 9.0 | 720 | 46 | 29 | 12.5 | 18 | 7.8 | 10 | 17.75 | 6.00 x 9.50 x 8.50 |
| 6-CIA | 506166 | UL/CSA | 1/3 | 230 | 4.5 | 720 | 46 | 29 | 12.5 | 18 | 7.8 | 8 | 18.50 | 6.00 x 9.50 x 8.50 |
| **6-CIA-RFS | 506171 | UL/CSA | 1/3 | 115 | 9.0 | 720 | 46 | 29 | 12.5 | 18 | 7.8 | 10 | 17.50 | 7.25 x 9.50 x 7.25 |

All models are 60 Hz. CIM – Manual CIA – Automatic

*Manual pump with RS-5 diaphragm switch included to convert to automatic operation.

**Manual pump with piggyback mechanical float switch included for automatic operation.

Continuous Duty Rated — "Little Giant Wastewater pumps are rated continuous duty as long as they are run within the published ratings for these pumps."

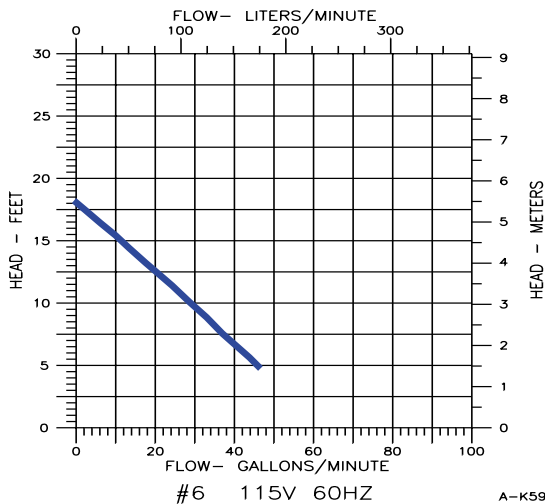

Construction

| | |
|-----------------------|--|
| Cover | Polycarbonate |
| Motor Housing | Epoxy Coated Cast Iron |
| Impeller Material | Nylon |
| Impeller Type | Non-Clog |
| Volute | Polypropylene |
| Power Cord | 18/3 SJOW-A |
| Mechanical Shaft Seal | Nitrile w/Carbon & Ceramic Faces |
| Fasteners | Stainless Steel |
| Shaft | Cold Rolled Steel |
| Bearings | Upper: Sintered Iron/Copper, Flanged Sleeve Lower: Sintered Iron/Copper, Flanged Sleeve |



Little Giant Pump Co.

PO Box 12010 • Oklahoma City, OK 73157

Phone: 405.947.2511 • Fax: 405.228.1550

E-mail: customerservice@littlegiant.com