

SPEAKMAN SAFETY PRODUCTS

Installation, Maintenance & Operation Instructions

SEF-1800 EYESAVER® FAUCET

DESCRIPTION

The SEF-1800 Eyesaver® faucet combines a gooseneck faucet with an independently operated eyewash. The faucet features ¼ turn Speakman Ceramic Perfect® Valves while the eyewash offers twin aerated sprays and flip top dust covers.

SPECIFICATIONS

OPERATION: Eyewash and faucet operate independently of each other

SUPPLY: ½" male connections for hot and cold inlets

WIDESPREAD VALVES: Perfect® valves with 1/4 turn ceramic cartridges covered by a 25 year warranty

FINISH: Chrome plated brass

FAUCET HANDLES: Vandal-resistant 4" wrist handles with color-coded indexes

EYEWASH ACTIVATION: Pull handle with graphics

EYEWASH SPRAYS: Aerated sprays.

FAUCET FLOW RATE: Autoflo® device controls flow to 2.2 GPM/ 8.3 LPM

EYEWASH FLOW RATE: 2.4 GPM at 30 psi. flowing. See flow data chart for additional information.

COUNTER THICKNESS: Up to 2" thick

CENTER DISTANCE: Adjustable centers of 6" to 12"

PRESSURE: 30 psi. minimum flow pressure, 125 psi. maximum static pressure

APPROVALS: Meets ASME A112.18.1, ANSI Z358.1 and CSA B125-98

VACUUM BREAKER (ST option): Approved by ASSE, UPC and CSA. Meets the ANSI/ASSE 1035

SHIPPING WEIGHT: 10 LBS.

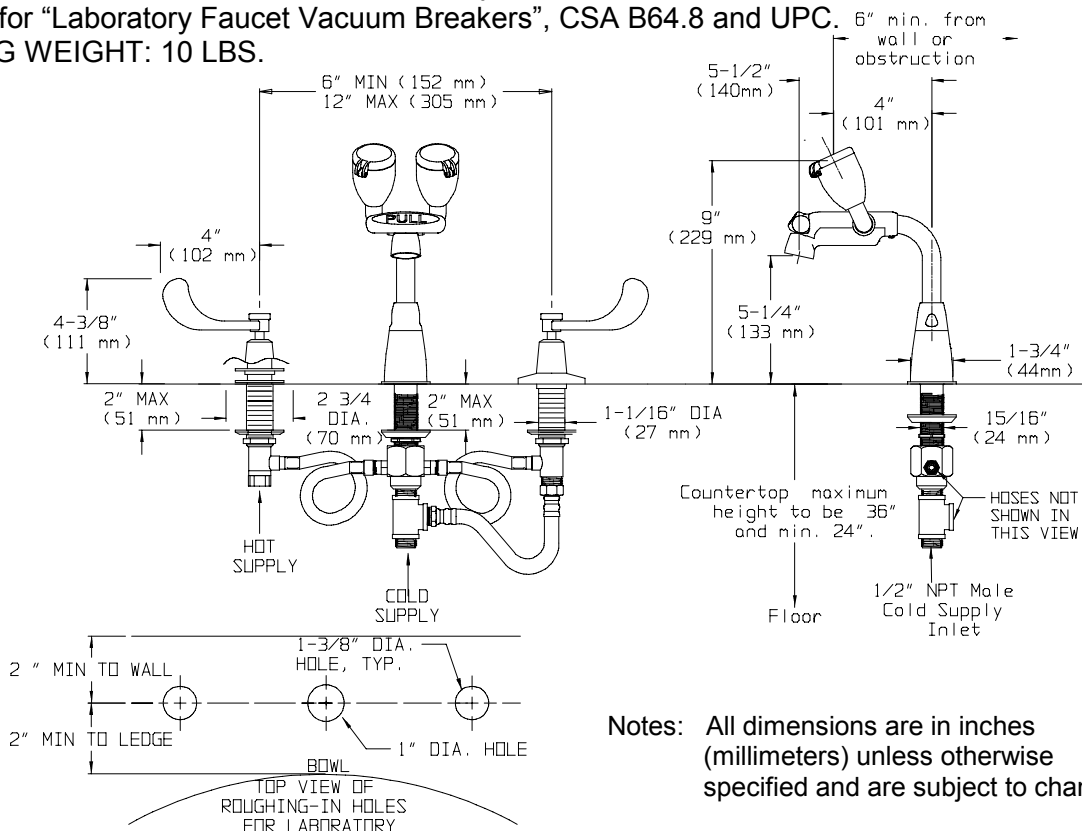

Notes: All dimensions are in inches (millimeters) unless otherwise specified and are subject to change.

IMPORTANT: The supply line for plumbed units shall provide an uninterrupted supply of flushing fluid at a minimum of 30 psi . of flow pressure. If shut off valve are installed in the supply line of the eyewash for maintenance purposes, provisions shall be made to prevent unauthorized shut off.



OPTIONS

◇ BOCA – Vandal-Resistant 0.5 gpm Flow Control	◇ 6WH – 6” Wrist Handles
◇ D75 – Diamond 75 Escutcheons	◇ LF – Laminar Flow Outlet 2.2gpm
◇ ST – Serrated Tip with Vacuum Breaker	

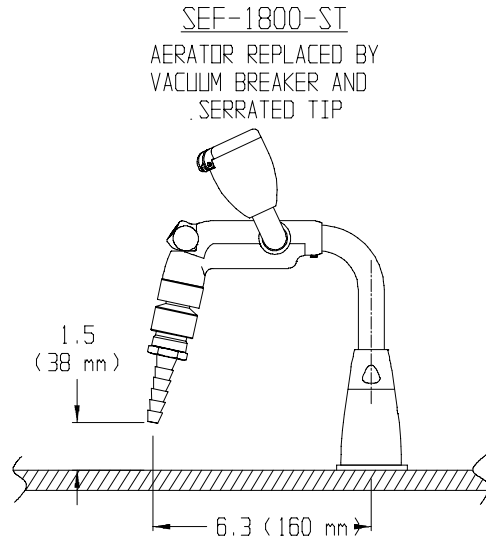

FLOW DATA

Flow Pressure-	psi. (BAR)	30 (2.07)	40 (2.76)	50 (3.45)	60 (4.14)	70 (4.83)	80 (5.52)
Flow Rate-	gpm (LPM)	2.43 (9.2)	2.75 (10.4)	2.8 (10.6)	3.01 (11.4)	3.22 (12.2)	3.5 (13.2)
Distance Eyewash Plume, 'A' -	ins. (cm.)	10-1/2 (26.7)	12-1/2 (31.7)	14 (35.6)	14-1/2 (36.8)	16 (40.6)	17-1/2 (44.4)

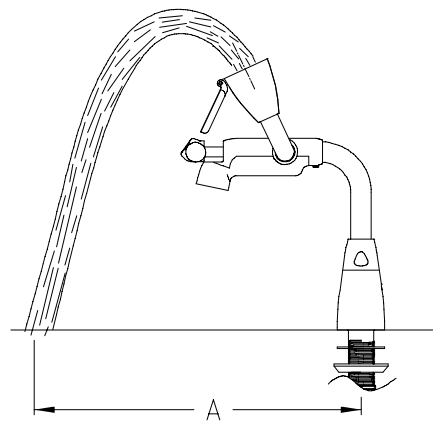

PACKING LIST

Item	Description	Qty.	Item	Description	Qty.
1	Valve Body Assembly, Hot side	1	9	Aerator	1
1b	Valve Body Assembly, Cold side	1	10	Handle and Trim package for – D75 option, (replaces item 2 & 3)	2
2	Trim Package	2	11	Handle package for – 6WH option, (replaces item 3)	2
3	Handle Package	2	12	Serrated Tip and Vacuum Breaker for –ST option, (replaces item 9)	1
4	Goosneck Assembly	1	13	.5 gpm aerator for – BOCA option, Item not shown (replaces item 9)	1
5	Washer Bag Group	1	14	Laminar flow outlet for – LF option, Item not shown (replaces item #9)	1
6	Valve Body Hose	2			
7	Adapter Tee Group	1			
8	½" Hose	1			

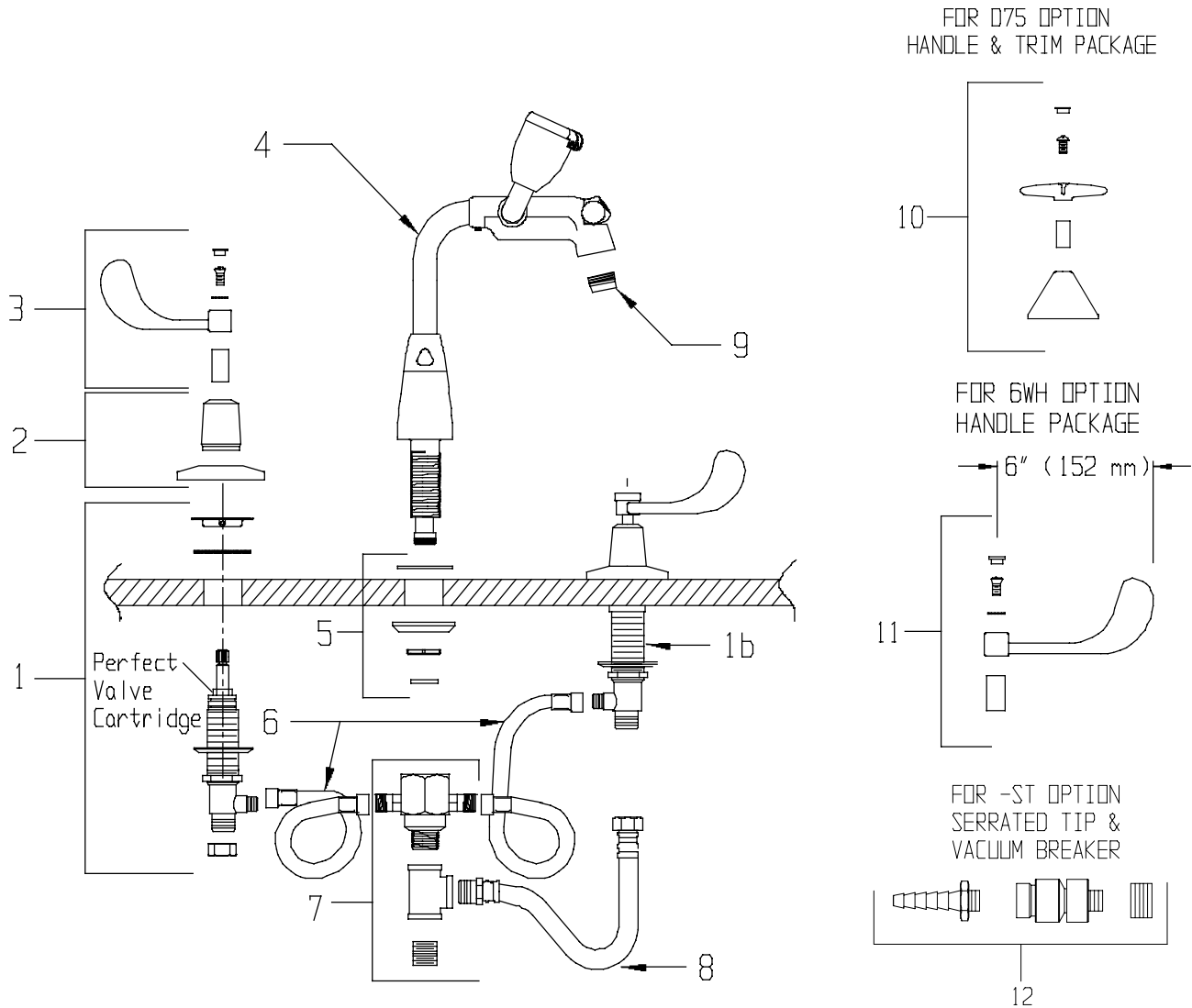

Step 1: Valve Body Mounting- The valve bodies are marked with red marker for the hot supply and blue marker for the cold supply.

- Screw locknuts down onto the valve body assemblies.
- Place the cup washers onto valve bodies.
- Working from below the sink, insert the valve body assemblies through holes in sink or countertop. From above sink, place rubber washers onto the valve bodies.
- Next, screw flange nuts onto valve bodies with flat side up, flush with top of valve bodies and tighten flange nut using the set-screw.
- From under sink, screw locknuts up hand tight. Position bodies so that outlets are accessible and wrench tighten locknuts while holding bodies in place.

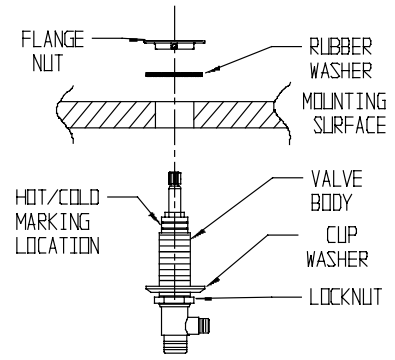

Step 2: Gooseneck Eyewash Mounting-

- Slip the base washer onto the gooseneck eyewash and slip through the center hole of the sink or countertop.
- The gooseneck eyewash swivels through 200° of rotation. Position the base of the gooseneck eyewash so the setscrew hole in the base is pointing towards the back of the sink or countertop. Note- For rigid gooseneck, position the gooseneck and tighten the setscrew in the mounting base. From below the sink slip the cup washer onto the shank and use the nut to tighten the assembly down onto the sink or countertop.
- Important-** Next insert the rubber seal into the adapter and screw the adapter onto the shank of the gooseneck eyewash until it bottoms out (Tape may be applied to the shank). If the adapter needs to be positioned for hose attachment, it can be backed off up to a maximum of 1 / 2 turn.
- Apply tape or sealant and connect the tee and nipple so that the tee outlets are accessible.

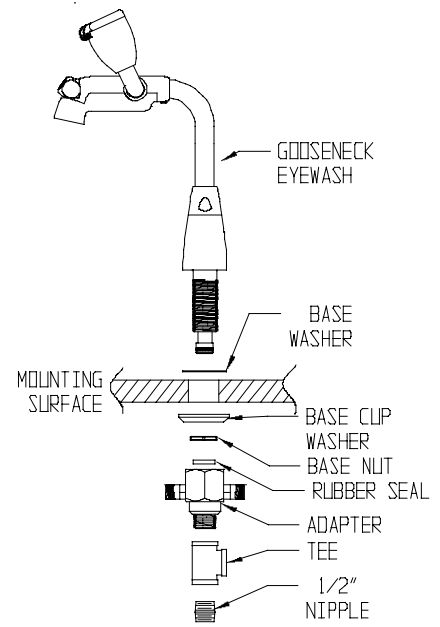

Step 3: Hose Connections-

- Screw valve body hoses onto the side outlets of the valve bodies and tighten. Screw the other end of the hoses onto base adapter.
- Apply tape to the male end of the 1/2" hose and connect to the side port of the tee as shown. Attach the other end to the cold side valve body inlet and tighten.
- Connect the vertical inlet of the tee to the cold water inlet supply.
- Connect the hot water supply line to the inlet of the hot water valve body and tighten the coupling nut.

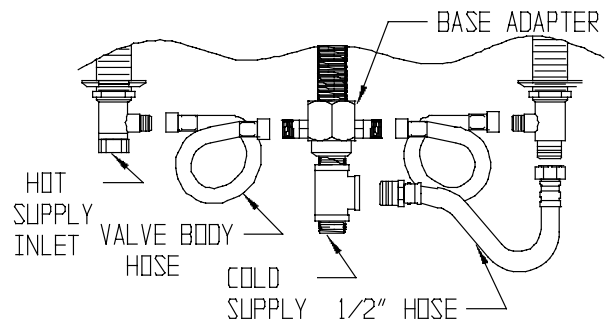

Step 4: Trim Package-

- From above sink, place the trim flange over the valve spindles.
- Screw trim collar onto the valve body and tighten. The flange should be secure at this point. If not, back off the flange nut that was assembled in step 1 and reassemble the trim.
- Slip sleeves onto valve spindles.
- Position the handles and secure using the lock washer and screw.
- Position the red index button on the handle for the hot water valve and press into place. Position the blue index button on the handle for the cold water valve and press into place.

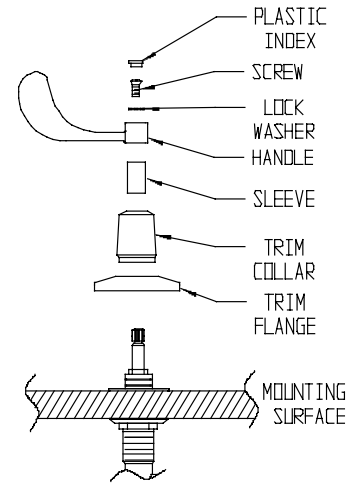

Step 5: Unit Flushing-

- After the assembly is complete, turn the hot and cold water supplies on and check for leaks.
- Activate the faucet to flush both the hot and cold sides of fixture. Check all connections for leaks.
- Install the aerator into the faucet outlet.
- At this time activate faucet and then activate the eyewash by pulling the handle and assure proper spray formation and no leaks.

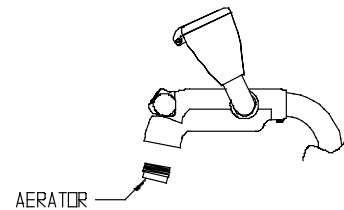

ALTERNATE INSTALLATION FOR DEDICATED TEPID WATER SUPPLY

The unit is designed so the eyewash has a dedicated supply line. This allows the eyewash to have a tepid water supply. For this type of installation, follow the installation instructions but do not assemble the tee, nipple and 1/2" hose (Steps 2d, 3b and 3c). Attach the tepid water supply to the center adapter as shown in the figure and your cold water supply to the cold valve body.

ANSI Z358.1-1998 requires that the delivered flushing fluid temperature shall be tepid. Also, in circumstances where chemical reaction is accelerated by flushing fluid temperature, a medical advisor should be consulted for the optimum temperature of each application.

IMPORTANT: The supply line for plumbed eyewash units shall provide an uninterrupted supply of flushing fluid at a minimum of 30 psi. of flow pressure. If shut off valve is installed in the supply line of the eyewash for maintenance purposes, provisions shall be made to prevent unauthorized shut off.

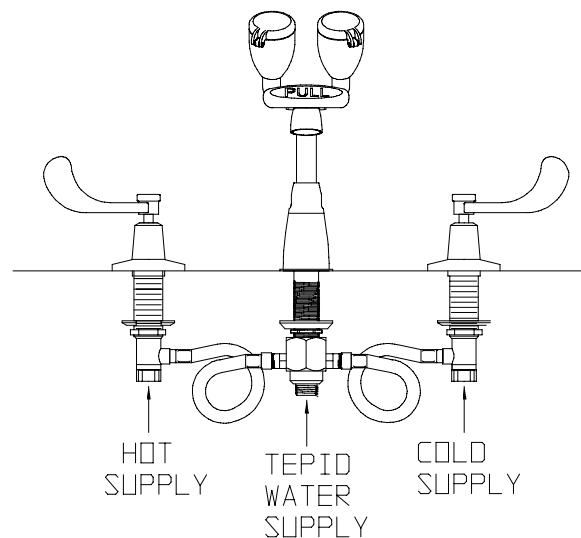

OPERATION

Faucet-Simply rotate the handles to operate the lavatory faucet.

Eyewash- The eyewash is activated by pulling the handle out. Once the eyewash is activated, the eyewash caps will flip off and water will come out of the aerated spray heads. The eyewash will continually discharge water until the handle is manually pushed back into the off position.

The flow of the individual spray heads is controlled by built-in flow controls. Each spray assembly is tested and aligned in the factory.

TESTING PROGRAM

ANSI Z358.1 requires that all emergency equipment shall be tested weekly to verify proper operation and inspected annually to assure conformance with ANSI Z358.1 - 1998 requirement.

MAINTENANCE (CARE and CLEANING)

End body valves are washer-less and require no routine maintenance. The gleaming finish of your SPEAKMAN Eyesaver[®] faucet can be cleaned by using mild soap and warm water. Rinse thoroughly and dry immediately with a soft, clean cloth for best results.

REPAIR PARTS LISTING

Part or Group Number	Description	Refer to Packing List Figure
RPG04-0316-PC	4" wrist handle group with screw and index buttons	Item 3
RPG10-0070-PC	Collar and flange	Item 2
RPG20-1895	End Body Assembly (red) with mounting hardware	Item 1 (hot supply)
RPG20-1894	End Body Assembly (blue) with mounting hardware	Item 1b (cold supply)
RPG05-0534	Perfect valve cartridge only (red)	Perfect valve cartridge (hot supply)
RPG05-0535	Perfect valve cartridge only (blue)	Perfect valve Cartridge (cold supply)
RPG38-0388	Yellow spray head and aerator repair parts assembly	Part of item 4
RPG49-0003	Repair parts for internal seals of the gooseneck eyewash	Not shown
G05-0724-PC	Faucet 2.2 gpm aerator	Item 9
RPG04-0366	Eyewash handle with yellow text and set screw	Part of item 4

