

SPEAKMAN COMPANY

SE-580 Installation, Maintenance & Operation Instructions

EYESAVER® EYEWASH

DESCRIPTION

Emergency eyewash, for wall mounting, supplied with plastic bowl, stay-open full flow ball valve; activated by stainless steel push handle; heavy duty wall mounting plate, twin spray heads with individual flow restrictors, and flip-off dust covers.

SPECIFICATIONS

BOWL: Polypropylene.

SPRAY HEADS: (2) Yellow ABS Plastic Spray Outlets, Sprayface, and Dust Covers.

VALVE: 1/2" NPT Female Brass, Chrome-Plated.

ACTIVATOR: Stainless Steel Push Handle.

INLET: 1/2" NPT Female.

PLATE: Cold-Rolled Steel, Painted Safety Green.

SHIPPING WEIGHT: 9.34 lbs.

EMERGENCY SIGN: 7-7/8" x 7-7/8" Plastic Wall Sign.

OPTIONS

◇ AL1 (Air Horn Alarm)	◇ HS (Hand-held Spray)	◇ SSBV2 (1/2" Stainless Steel Valve)
◇ AL2 (Electrical Alarm)	◇ PT (P-Trap)	◇ ILS (In-Line Strainer)
◇ AL3 (Electrical Alarm)	◇ SGN4 (Eye Wash Floor Sign)	◇
◇ AL2-C1D2 (Electrical Alarm / Haz. Area)	◇ FPV (Anti-Freeze Protection Valve)	◇
◇ AL3-C1D2 (Electrical Alarm / Haz. Area)	◇ SPV (Anti-Scald Protection Valve)	◇
◇ FLW (Flow Switch)	◇ VPL (Vapor Proof Light)	◇

INSTALLATION

Review drawing (as shown on other side) to assure proper installation. The unit should be mounted to a structural member that will ensure structural rigidity. Use appropriate wall anchors and be sure the wall bracket is level to ensure proper flow pattern and to avoid unnecessary water spillage. Connect a water supply to the unit (use pipe sealant on all joints) that is a 1/2" minimum uninterrupted source of potable water. Failure to use potable water can result in emergency units producing impure or contaminated water causing possible further injury. The drain tailpiece or waste should be connected to an adequate drain in compliance with local plumbing codes.

OPERATION

The eyewash is activated by pushing the push handle back 90°. The unit will operate until the push handle is manually pulled back up to the off position.

TESTING PROGRAM

The American National Standards Institute (ANSI) states that all safety emergency equipment shall be activated on a weekly basis to flush the line and verify proper operation. Speakman Company furnishes a testing record tag (91-0635) with each unit. On this tag the date of inspection and the inspectors initials should be noted.

MAINTENANCE

The valve and the eyewash are the only portions of the unit that may require maintenance. Should you need parts to repair this unit, please reference the parts listing below for correct part numbers. Reference additional technical sheet (supplied) for information on the SE-910 ball valve.

Before any maintenance is done **be sure to shut the water supply off.**

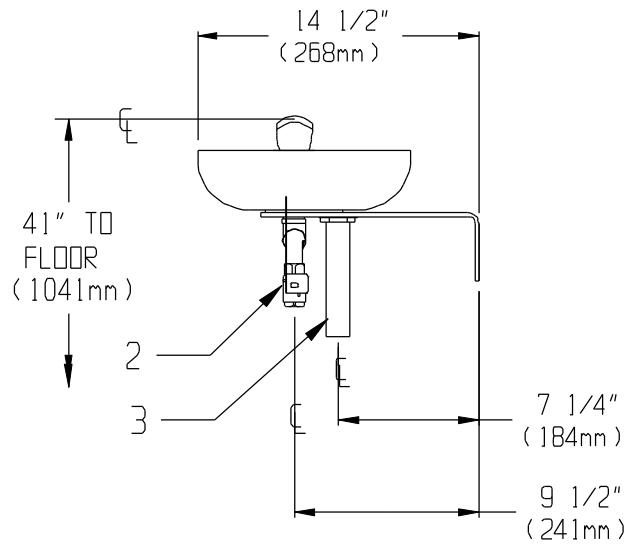
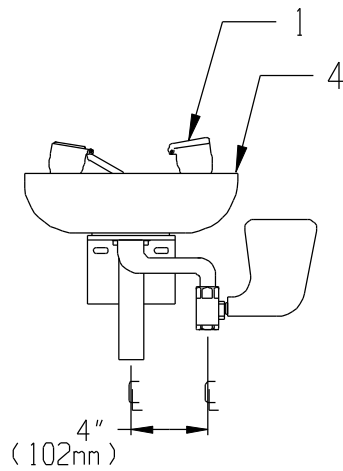

WARNING: Use only genuine Speakman parts when repairing or replacing components. To order parts call 1-800-537-2107.

SE-580 REPLACEMENT/REPAIR PARTS

<u>ITEM</u>	<u>PART/GROUP #</u>	<u>DESCRIPTION</u>
1	G05-0714	Aerated Bullhorn & Sprayhead Assy.
2	SE-910	1/2" Stay-Open Ball Valve with Paddle Handle
3	43-0642	Drain Pipe
4	68-0034	Round Plastic Bowl

FLOW DATA

EYEWASH:

FLOW PRESSURE	PSI (BAR)	30 (2.07)
FLOW RATE	GPM (LPM)	3.6 (15)

NOTE: This unit should be connected to an uninterrupted source of potable water, with a minimum flowing pressure of 30 PSI and a maximum static pressure of 125 PSI.

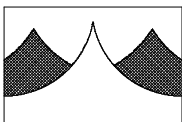

SPEAKMAN COMPANY
 The Quality leader Since 1869
 P.O. Box 191, Wilmington, DE 19899-0191 USA
 1-800-537-2107, Fax: 1-800-977-2747

Note: All units meet existing ANSI Z358.1 1998 Standards and OSHA Rules. Product improvements may cause specification and dimensional changes without notice.