

SPEAKMAN®

SE-580 EYESAVER® EYEWASH

DESCRIPTION

SE-580 Eyesaver® eyewash features a plastic bowl, dual aerated spray heads with automatic flow controls and flip top dust covers.

SPECIFICATIONS

BOWL: Polypropylene.
SPRAY HEADS: (2) Yellow ABS Plastic Spray Outlets, Sprayface, and Dust Covers.
VALVE: 1/2" NPT Female Brass, Chrome-Plated.
ACTIVATOR: Stainless Steel Push Handle.
INLET: 1/2" NPT Female.
PLATE: Cold-Rolled Steel, Painted Safety Green.



Universal Emergency Sign Included
Compliance: Meets ANSI Z358.1-1998

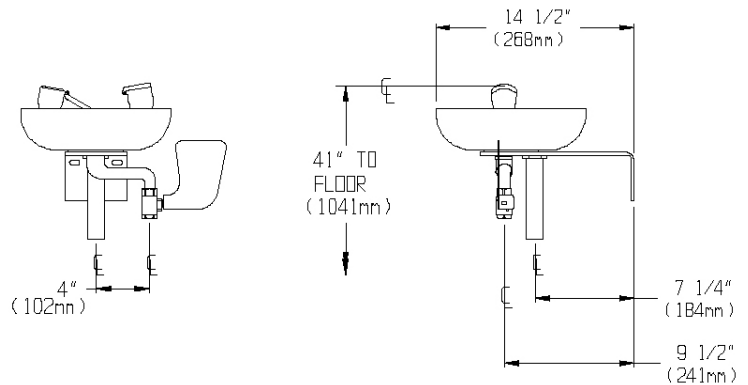

OPTIONS

- Hand Foot Operation (HFO)
- Freeze Protection Valve (FPV)
- Scald Protection Valve (SPV)
- Flow Switch (FLW)
- Hand Held Spray (HS)
- P-Trap (PT)
- Stainless Steel Ball Valve (SSBV)
- In Line Strainer (ILS)

Job Name _____
Location _____
Architect/Engineer _____
Sales Representative _____
Wholesaler _____
Date _____ Model # _____