

Watts Series N55B-M1

1/2" - 1" (15-25mm)

Installation Instructions

1. The valve should be installed by a licensed contractor in accordance with local codes and ordinances. This valve should be installed where it is accessible with sufficient clearance for cleaning, service, or adjustment.
2. Before installing the valve, be sure that the pipe ends are reamed and threads are cut to size.
3. Flush the lines to remove all loose scale, dirt and other foreign matter that can damage or clog the valve.
4. Install the regulator with the arrow on the body pointing in the direction of the flow.
5. Regulator may be installed vertically or horizontally (upright or inverted).
6. Start Up — Open cold water supply then hot water supply. Inspect for leaks.

Note: The valve should be inspected annually to assure maximum life and performance.

Note: N55B-M1 — These valves are suitable for outdoors or PIT installations.



N55BU-M1

Typical Installation

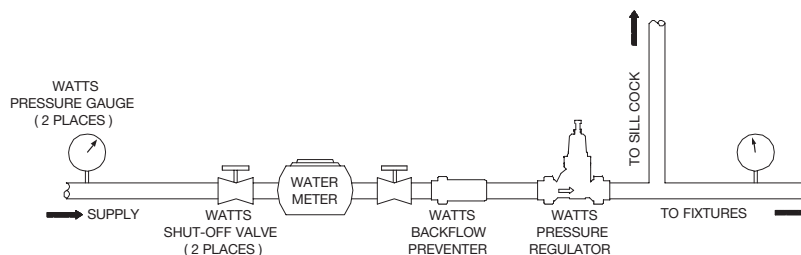

Series Installation

Series installations are recommended where very high supply pressure must be reduced to a very low downstream pressure. Reducing the pressure in stages eliminates whistling and noise.

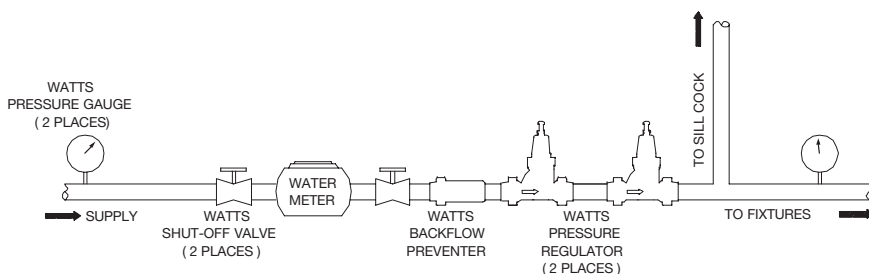

Parallel Installation

Parallel installations are recommended where high flow or low flow demand is intermittent/occasional. They are also used for installations where service cannot be interrupted.

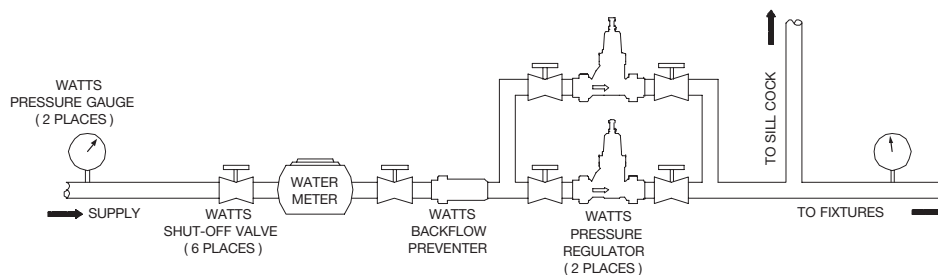

Maintenance Instructions

- To clean strainer or replace seat/stem module shut off supply, loosen Locknut and Lock Seal and back off Adjusting Screw.
- Remove Spring Cage, Spring, Washer and Slip Ring. Grasp Stem Nut with fingers or pliers and lift module from body.
- Replace module and reassemble valve.
- Readjust pressure setting.

Adjustment

Regulator is factory preset to 50psi. To adjust pressure setting, loosen the lock nut and turn the adjusting bolt clockwise to increase pressure, counter clockwise to decrease pressure.

Note: Use a pressure gauge downstream to adjust and verify the pressure setting.

By-Pass Feature*

This regulator has a built-in thermal expansion by-pass feature. This feature prevents downstream pressure from rising to more than 10psi above the supply pressure.

* By-Pass will not work if inlet pressure is above 150psi (10.34 bar).

Troubleshooting

High System Pressure

If the downstream system pressure is higher than the set pressure under no flow conditions, the cause could be thermal expansion, pressure creep or dirt/debris on the seat.

Thermal expansion occurs whenever water is heated in a closed system. The system is closed when supply pressure exceeds 150psi, or a check valve or backflow preventer is installed in the supply piping.

You must make provisions for pressure relief protection of your plumbing system and components. The use of a relief valve such as the Watts 530C, BRV, Governor 80, or 3L or potable water expansion tank such as the Watts DET, PLT or DETA may be required.

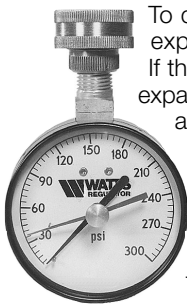

Watts 276H300

To determine if this is the result of thermal expansion, try briefly opening the cold water tap. If the increased pressure is caused by thermal expansion, the pressure will immediately be relieved and the system will return to the set pressure. Watts offers a pressure test gauge, model 276H300 to assist you in determining if you have high water pressure. The 276H300 when attached to a hose bibb registers the highest pressure reading over the period of time it is left on the system.

SEAT/STEM MODULE

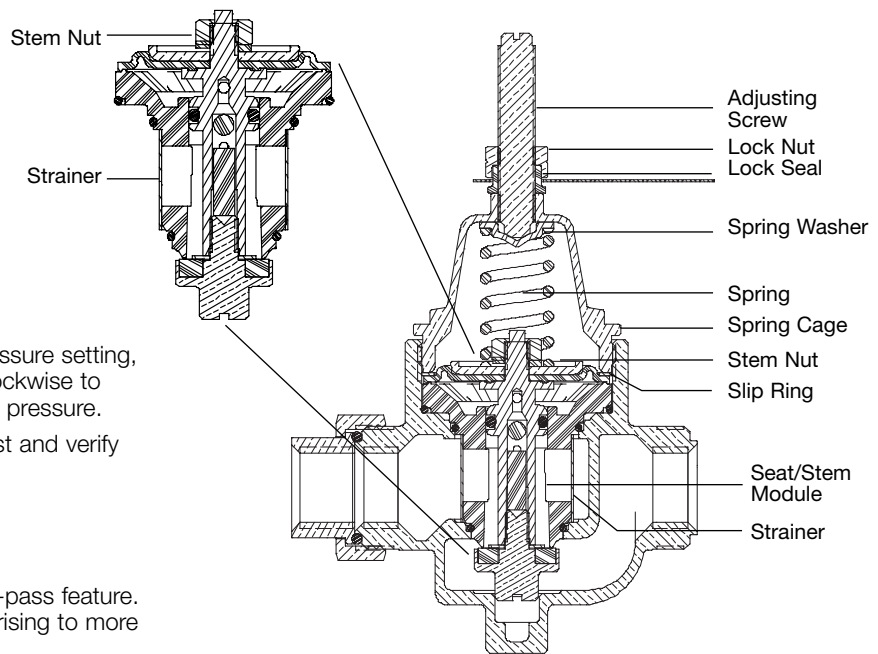

Repair Kit

KIT NO.	SIZE		ORDERING CODE	KIT INCLUDES
	in.	mm		
½ - 1 N55B-RK	½, ¾, 1	15, 20, 25	0007723	Seat/Stem Module

WARNING!

For valves with CPVC or PEX end connections do not exceed the tubing manufacturers pressure and temperature ratings. Refer to the tubing manufacturers product specifications for that information.

CALIFORNIA PROPOSITION 65 WARNING

WARNING: This product contains chemicals known to the State of California to cause cancer and birth defects or other reproductive harm. (California law requires this warning to be given to customers in the State of California.)

For more information: www.watts.com/prop65



USA: 815 Chestnut St., No. Andover, MA 01845-6098; www.wattsreg.com

Canada: 5435 North Service Rd., Burlington, ONT L7L 5H7; www.wattscanada.ca

Limited Warranty: Watts Regulator Company warrants each product to be free from defects in material and workmanship under normal usage for a period of one year from the date of original shipment. In the event of such defects within the warranty period, the Company will, at its option, replace or recondition the product without charge. This shall constitute the sole and exclusive remedy for breach of warranty, and the Company shall not be responsible for any incidental, special or consequential damages, including without limitation, lost profits or the cost of repairing or replacing other property which is damaged if this product does not work properly, other costs resulting from labor charges, delays, vandalism, negligence, fouling caused by foreign material, damage from adverse water conditions, chemical, or any other circumstances over which the Company has no control. This warranty shall be invalidated by any abuse, misuse, misapplication or improper installation of the product. **THIS WARRANTY IS IN LIEU OF ALL OTHER WARRANTIES, EXPRESS OR IMPLIED, INCLUDING ANY IMPLIED WARRANTIES OF MERCHANTABILITY OR FITNESS FOR A PARTICULAR PURPOSE.** Any implied warranties that are imposed by law are limited in duration to one year.

Some States do not allow limitations on how long an implied warranty lasts, and some States do not allow the exclusion or limitation of incidental or consequential damages. Therefore the above limitations may not apply to you. This Limited Warranty gives you specific legal rights, and you may have other rights that vary from State to State. You should consult applicable state laws to determine your rights.