



Residential Energy Saver Electric-Utility

Features:



Bradford White is ISO registered to the 9001- standard.

- All residential storage models above 20 gallon capacity meet or exceed efficiency requirements of the Department of Energy. ASHRAE Standard 90.1 b (current standard) and the National Appliance Energy Conservation Act of 1987 recent amendment effective January 20, 2004 which supercedes all state and local efficiency requirements.
- **1" Non-CFC foam insulation**—completely covers the side and top of tank, saving energy by retarding loss of heat (Except M-2-30 2").
- **Factory installed dielectric waterway fittings**—located on the side (6 and 12 gallon models come equipped with alternate water connection tapings on the top) for easier installation.
- **Fully automatic controls**—Fast acting surface-mount thermostat for automatic temperature control. Factory installed sensitive manual reset energy cut-off for safety to prevent overheating.
- **Direct heat transfer with immersed element**—transfers heat directly and efficiently to the water. Screw-in style.
- **Vitraglas® lining**—Bradford White water heater tanks are protected from the corrosive effects of hot water by an exclusive ceramic porcelain-like coating. The Bradford White high silica Vitraglas® lining provides a tough interior surface for our hot water tanks.
- **Protective magnesium anode rod**—provides added protection against corrosion for long trouble-free service.
- **T&P relief valve included**—all models have special tapping on side of tank.
- **Six or ten year limited warranty on steel tank**—heavy gauge steel automatically formed, rolled and welded to assure a continuous seam for glass lining.
- **Six year limited warranty on parts.**

MANUFACTURED UNDER ONE OR MORE OF THE FOLLOWING U.S. PATENTS: 5,954,492; 5,761,379; 5,943,984; 5,081,696; 5,988,117; 6,142,216; 5,199,385; 6,684,821; 5,574,822; 5,372,185; 5,485,879; 5,277,171; (B1)5,341,770; 5,660,765; 5,596,952; 5,682,666; 4,904,428; 5,023,031; 5,000,893; 4,669,448; 4,829,983; 4,808,356; 5,115,767; 5,092,519; 5,052,346; 4,416,222; 4,628,184; 4,861,968; 4,672,919; Re. 34,534. OTHER U.S. AND FOREIGN PATENT APPLICATIONS PENDING. CURRENT CANADIAN PATENTS: 1,272,914; 1,280,043; 1,289,832; 2,045,862; 2,112,515; 2,108,186; 2,107,012.



Residential Energy Saver Electric-Utility

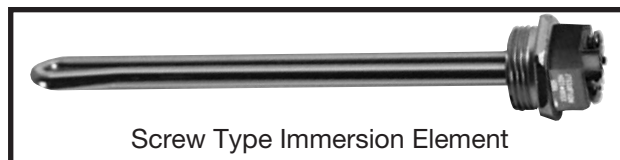

Screw Type Immersion Element

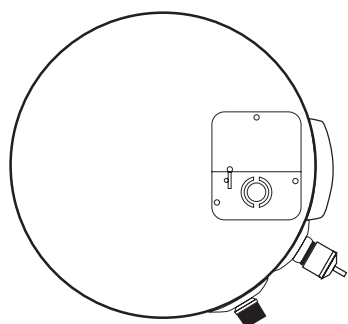

Top View
20 & 30 Gallon Models

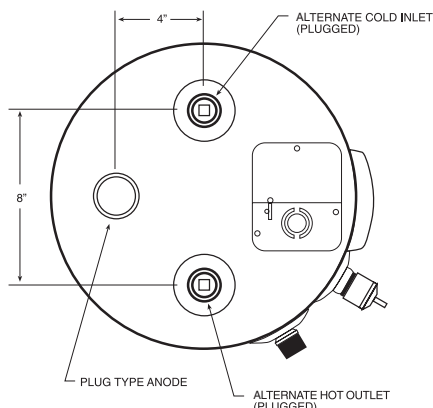

Top View
6 & 12 Gallon Models

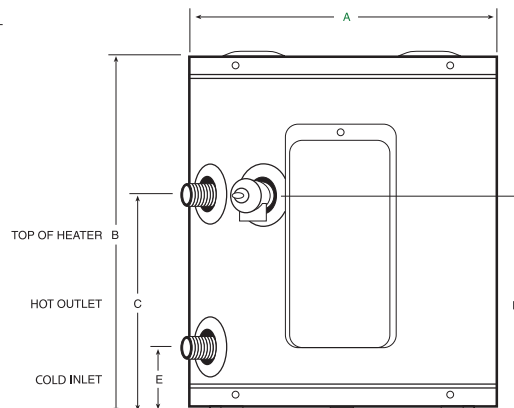

6 & 12 Gallon Models

Utility Electric Models

Model	Imp. Gal. Cap.	U.S. Gal. Cap.	Liters	Recovery Per Hour 50°C. Rise 90°F. Rise			A Jacket Diam.		B Height Floor to Heater Top		C Height Floor to Hot Water Conn.		D Height Floor to T&P Conn.		E Height Floor to Cold Water Conn.		Approx. Shipping Weight	
				Imp. Gal.	U.S. Gal.	Liters/ Hour	in	mm	in	mm	in	mm	in	mm	in	mm	Lbs.	Kg.
M-1-6U6SS	5	6	23	6	7	26	14	356	16½	419	10½	257	10½	257	3½	79	33	15
M-1-12U6SS	10	12	45	6	7	26	14	356	27¾	705	21½	537	21½	537	3	76	48	22
M-1-20U6SS	16	19	72	6	7	26	18	457	24¾	629	18¾	464	18¾	464	3	76	59	27
M-2-30U6SS	25	30	114	6	7	26	22	557	30	762	23½	597	23½	597	4½	114	82	37

Note: The Utility modes are wired standard for 120 volt with a 1500 watt element. Please specify 240 volt wiring if desired and element wattage. 1500 watt/120 volt element requires a 20 Amp breaker. Maximum wattage for 6 and 12 gallon (23 and 45 liter) sizes is 3000W. Maximum wattage for 19 and 30 gallon (72 and 114 liter) sizes is 3000W at 120V or 6000W at 208, 240, 277 and 480 unless otherwise specified. Other wattages and voltages are available.

General

All models UL and CUL listed. Applicable models CSA verified for energy performance in accordance with C191.1-M90. All water connections ¾" (19mm) NPT. All electrical connections ¾" (19mm). All models certified at 300 psi (2068 kPa) test pressure, 150 psi (1034 kPa) working pressure. Change suffix number 6 to 10 for warranty identification. Suffix letter "S" indicates screw type element.

Dimensions and specifications subject to change without notice in accordance with our policy of continuous product improvement.

6-Year Limited Warranty on Component Parts

BRADFORD WHITE CORPORATION has a 6-year warranty on replaceable parts—thermostat, element, dip tube. These quality components are manufactured for us by industry leaders and will be replaced in the event of failure during the parts warranty period (exclusive of shipping and re-installation cost.)*

6 or 10-Year Limited Tank Warranties

BRADFORD WHITE CORPORATION LIMITED WARRANTY: Protects your investment in a quality glass-lined water heater. If the tank leaks for reasons of faulty materials, workmanship, or corrosion within the warranty period, the heater will be replaced with a comparable heater of our manufacture (exclusive of shipping and re-installation cost.)*

* Some states and provinces do not allow limitations on warranties. See complete copy of the warranty included with the product. Indicated warranties apply to USA, Canada and Puerto Rico installations.

Vitraglas® is a registered trademark of Bradford White® Corporation.
©2004, Bradford White Corporation. All rights reserved.



Ambler, PA
For U.S. and Canada field service, contact your professional installer or local Bradford White sales representative.

Sales/800-523-2931
Fax/215-641-1670

Technical Support/800-334-3393
Fax/269-795-1089

Warranty/800-531-2111
Fax/269-795-1089

International:
Telephone/215-641-9400
Telefax/215-641-9750

Fax on Demand:
888-538-7833

www.bradfordwhite.com



Mississauga, ON
Sales/Technical Support
866-690-0961
905-238-0100

Fax/905-238-0105

www.bradfordwhitecanada.com

Count On Bradford White
For *Everything* Hot Water